

Mineral Insulated (MgO) Thermocouples

Style D – Quick Disconnect Assembly

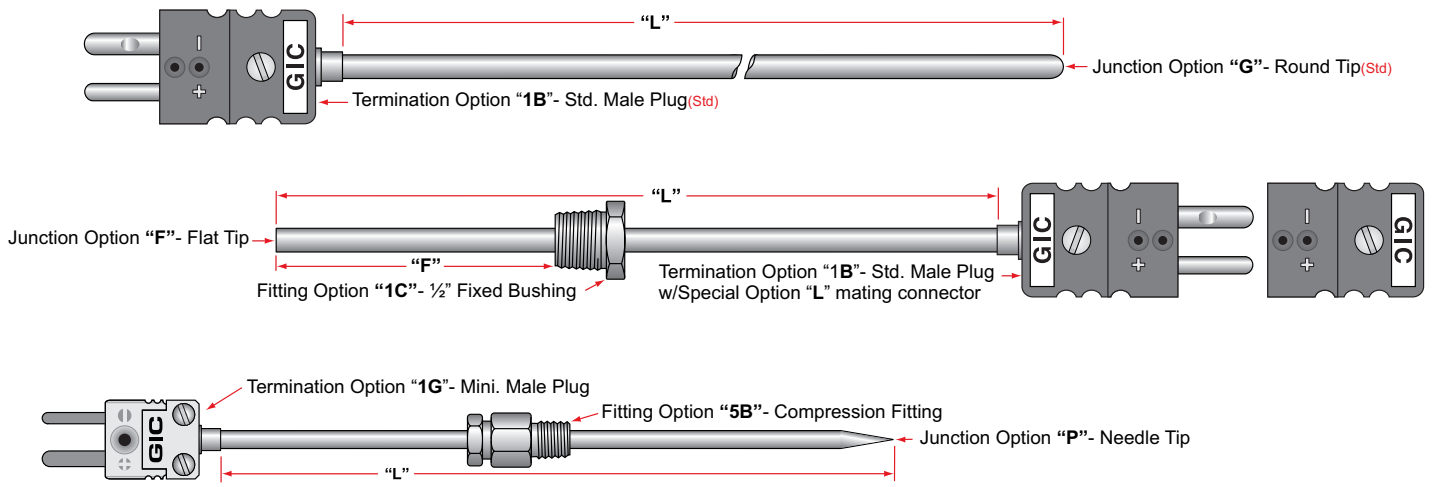

1. Calibration (See page 13 for other cal's)

J = Type J (1400°F) T = Type T (700°F)
K = Type K (2300°F) E = Type E (1600°F)

2. Junction (See Diagram TS-TC)

	Grounded	Ungrounded
Round Tip	G (Std)	U
Flat Tip	F	B
118° Drill Tip	D	C
Needle Tip	P	M
Reduced Tip	R	Q
Exposed Tip	-	E

3. Element Type (See page 14)

A = Single B = Duplex*
* Common Ungrounded is Standard for Ungrounded Junctions
For Separated Ungrounded choose "O" under Special Options

4. Sheath Operating Temperature

A = -200°C to 260°C (500°F) D = 0°C to 900°C (1650°F)
B = -200°C to 400°C (750°F) E = 0°C to 1150°C (2100°F)
C = -200°C to 600°C (1200°F) Z = Other

5. Sheath Material (See page 14 for other Materials)

4 = 304SS (1650°F)(Std) 0 = 310SS (2100°F)
6 = 316SS (1650°F) I = INCONEL (2150°F)

6. Sheath Diameter (Metric sizes also available)

A = .010 D = .040 H = .188* M = .375
B = .020 F = .063* I = .250* P = .500
C = .032 G = .125 Q = .313 Z = Other * Quick delivery

7. Sheath Length "L" (Example 12.5 = 12 1/2 inches)

0.25 - 999 inches Z = greater than 999 inches (Consult Factory)

Attention OEMs: GIC uses the highest quality connectors on our Style D assemblies. But if you have a specific brand that you would rather we use just let us know. GIC builds assemblies with most of the major brands of connectors.

www.GICThermodynamics.com

Diagram BEND

INFORMATION FOR ORDERING A SENSOR WITH A BEND

Factory Bend Standards:

For 45° bends "C" is measured from the tip to the start of the bend.

For 90° bends "C" is measured from the tip to the centerline of the sheath.

For Bends other than 45° or 90° consult factory.

Chart - RD

SHEATH DIAMETER	BEND RADIUS
1/8" (.125)	3/8" Radius
3/16" (.188)	7/16" Radius
1/4" (.250)	9/16" Radius
3/8" (.375)	15/16" Radius
1/2" (.500)	1-1/2" Radius

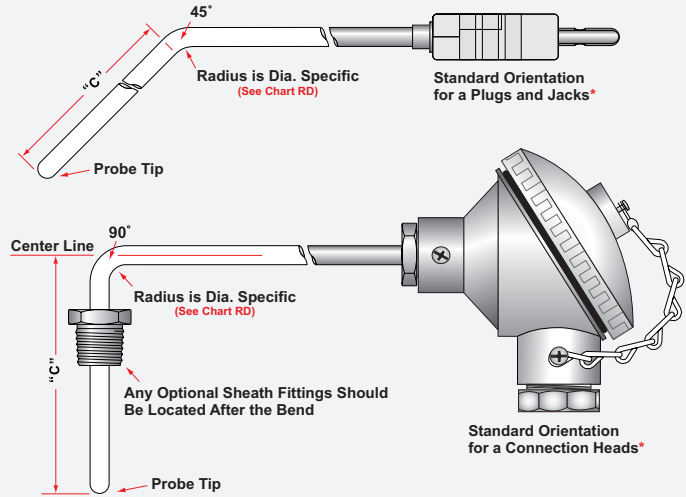

Notes:

For RTD's the minimum "C" dimension is the length of the element plus 1/2".

*For Orientations of terminations other than standard consult factory.

13. Bend Location "C" (Inches from tip, see "Diagram BEND") N = No Bend(Std)

12. Bend Angle

N = None(Std) G = 45 Degree Bend S = 90 Degree Bend Z = Other

11. Special Options (Choose all that apply - See Page 15 for more Options)

N = None
 A = Special Limits of Error
 L = Mating Connector
 P = Electro-etching
 T = Coated Probe
 O = Separate Ungrounded Junctions
R = Faster Response Construction
 Y = Certificate of Conformance
 X = X-Ray Junction
 Z = Other (Consult Factory)

10. Fitting Location "F" (Inches from tip) N = No Fitting Location (Std)

9. Fittings (See page 18 for more info and other fittings) (Metric fittings also available)

N = None (Std) FB = Fixed Bayonet Fitting (.188 and .250 Dia only) Z = Special

NPT Fittings	1/8" NPT	1/4" NPT	1/2" NPT	3/4" NPT	SPECIAL
Fixed Bushing (Stainless)	1A	1B	1C	1D	1Z
Fixed Hex Nipple (Steel)	2A	2B	2C	2D	2Z
Fixed Hex Nipple (Stainless)	3A	3B	3C	3D	3Z
Spring Loaded Hex Nipple (Stainless)	-	-	4C	-	4Z
Compression (Brass) one time adj.	5A	5B	5C	-	5Z
Compression (Stainless) one time adj.	6A	6B	6C	-	6Z
Compression (Stainless) re-adjustable*	7A	7B	7C	-	7Z

*Teflon® gland standard (400°F) for other gland options such as Lava (1200°F) see page 18

Diagram TS-TC (see page 15)

Junction Tip Style	Grounded Junction	Ungrounded Junction
Round Tip	G(Std)	U
Flat Tip	F	B
118° Drill Tip	D	C
Needle Tip	P	M
Reduced Tips	R	Q
Exposed Tip	-	E

8. Terminations (See page 16 for more information)

PLUGS & JACKS

	Std Temp (425°F)	Hi-Temp (660°F)	Ceramic (1200°F)
Std Male Plug	1B	2B	3B
Std Female Jack	1D	2D	3D
Mini Male Plug	1G	2G	3G
Mini Female Jack	1L	2L	3L

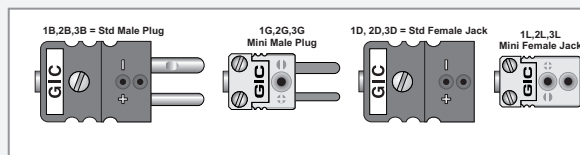

Thermocouple Assemblies

When It Comes to Thermocouples “There IS a Difference”!

Thermocouples are the most common and versatile sensors used to measure temperature. They can be designed to work in any application where a temperature measurement is required ranging from minus 300 °F to over 4000 °F.

Thermocouples operate on the principle of thermal emf (Electromotive Force). Thomas Seebeck observed in 1821 that two dissimilar metal wires, if joined at both ends, produce a current when the junctions are at different temperatures. The current produced is a function of the junction temperature and the type of metals used. This relationship between thermal emf and temperature is now known as the Seebeck effect.

The thermal emf can be measured by breaking the thermocouple loop at any point and measuring the open circuit voltage. For example, a thermocouple, made of Chromel/Alumel metals (Type K) generates about 40 microvolts per degree Celsius.

The voltage/temperature relationship varies depending on the metals used. The metal combinations used depend on the output voltage required and the temperature range monitored. ANSI Thermocouples are tested and graded against the American National Standards Institute standards and are available in Standard and Special Limits grades (see table below). The Special Limits grade has only half the error of the Standard grade and is recommended for high temperature applications.

Thermocouples are considered to be “tip sensitive” because they measure temperature at the junction, which is located at the end or tip of the sensor. Care should be given when considering the best assembly to fit an application. To acquire accurate temperature readings careful consideration should be given to the design and sensor location in the process. (See inside back cover for “Thermocouple Installation & Maintenance Suggestions”)

GIC Thermodynamics’ sales and engineering staff will assist you with designing the best thermocouple sensor style to fit your process and application. Selecting the proper sensor style is very important, as each application or process has its own specific inherent problems that require careful consideration in order to determine the sensors life, accuracy, and dependability. When choosing a sensor it is important to consider its location, temperature range, accuracy required, how rapidly the temperature cycles, heat conduction, process environment, vibration, and ease of installation. If you need additional assistance with the selection of a sensor for your application, please feel free to contact our sales and engineering staff.

ANSI Conductor Characteristics: Temperature & Limits of Error

ISA CODE	CONDUCTOR & CHARACTERISTICS		TEMPERATURE RANGE (F)	LIMITS OF ERROR		APPLICATION NOTES
	POSITIVE	NEGATIVE		STANDARD	SPECIAL	
J	Iron (magnetic)	Constantan (non-magnetic)	0 to 530 F 530 to 1400 F	+/- 4F +/- 3/4%	+/- 2F +/- 3/8%	Reducing atmosphere recommended. Iron oxides rapidly at elevated temperatures.
T	Copper (non-magnetic)	Constantan (non-magnetic)	-75 to 200 F 200 to 700 F	+/- 1-1/2F +/- 3/4%	+/- 3/4F +/- 3/8%	Can be used in oxidizing or reducing atmospheres rust and corrosion resistant. Fine for low temperatures & Cryogenic.
K	Chromel (non-magnetic)	Alumel (magnetic)	0 to 530 F 530 to 2300 F	+/- 4F +/- 3/4%	+/- 2F +/- 3/8%	Oxidizing atmosphere recommended. Vented protection tube suggested in reducing atmosphere.
E	Chromel (non-magnetic)	Constantan (non-magnetic)	0 to 600 F 600 to 1600 F	+/- 3F +/- 1/2%	+/- 3/8%	Oxidizing atmosphere recommended. Highest EMF output of thermocouples commonly used.
S	Platinum 10% Rhodium (non-magnetic)	Platinum (non-magnetic)	0 to 1200 F 1200 to 2700 F	+/- 5F +/- 1/2%	+/- 2-1/2F +/- 1/4%	Oxidizing atmosphere recommended. Easily contaminated. The accepted laboratory standard in premium grade due to its reproducibility.
R	Platinum 13% Rhodium (non-magnetic)	Platinum (non-magnetic)	0 to 1200 F 1200 to 2700 F	+/- 3F +/- 1/4%	+/- 1F +/- 1/10%	Same conditions as 10% above but has 13% Rhodium slightly higher emf. Mostly used in industrial applications.
N	Nicrosil (non-magnetic)	Nisil (non-magnetic)	0 to 530 F 530 to 2300 F	+/- 4F +/- 3/4%	+/- 2F +/- 3/8%	Better Resistance to Oxidation and longer life at high temperatures than Type K.
B	Platinum 30% Rhodium	Platinum	1000 to 3200 F	+/- 1/2%	+/- 1/2%	Can be used in a vacuum with limited life.

Special Note:

Certain characteristics and tolerances of thermocouple materials change over time and usage, including the EMF vs Temperature relationship. As a result of these changes it is not recommended to recalibrate used sensors once they are out of tolerance. The useful life of a thermocouple depends on several factors including wire gauge, environment and temperature range. For longer sensor life, we recommend using the largest diameter probe possible. But consider the larger the diameter the slower the response time (See Approximate MgO Response time chart on page 14).

Mineral Insulated (MgO) Thermocouples

Magnesium Oxide (MgO) Insulated Thermocouples

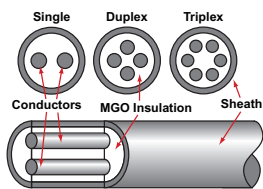

MgO thermocouples offer the greatest variety of features of all styles of thermocouples making them the best choice for most applications. They are made in all calibrations with a wide variety of sheath diameters and materials. MgO assemblies are fully annealed and field bendable. They can be bent to a minimum radius of twice the sheath diameter without damage to the insulation and mounting hardware can be brazed or welded to the sheath.

MgO sensors are recommended where a moisture proof, non-porous insulation is required, and for applications where high pressure, high vibration and high temperature conditions are encountered. These variations make them the logical choice for applications from test labs to heavy industry.

GIC uses only High Purity MgO in our assemblies which is recommended for high temperature applications. MgO filled metal insulated thermocouples are available in sizes from 0.010 to 0.500 inch diameters. Choosing the proper diameter for an application depends on the process environment, process temperatures, and desired response time. A good rule to consider is the higher the temperature the larger the diameter probe. Also, the faster the response time required the smaller the diameter, providing high temperatures are not involved. For ungrounded sensor with a faster response time see GIC's new "Faster Response Time" (Page 4)

Approximate MgO Response times

MgO Diameter	Grounded Junction	Ungrounded Junction
.020	.10 Sec.	.40 Sec.
.032	.14 Sec.	.50 Sec.
.040	.19 Sec.	.65 Sec.
.063	.22 Sec.	.75 Sec.
.090	.37 Sec.	.88 Sec.
.125	.52 Sec.	1.25 Sec.
.188	1.00 Sec.	2.40 Sec.
.250	2.20 Sec.	4.30 Sec.
20 Gauge Bare wire	.45 Sec.	-
14 Gauge Bare wire	.50 Sec.	-

Diagram SM

Sheath Materials

The sheath material gives the MgO insulation its protection from the environment, contamination and potential mechanical damage. There is no material that is appropriate for all applications; you must consider the process temperature, corrosiveness, mechanical strength, cost and intended service life when selecting the material.

- 304SS (4)** maximum temperature is 1650 deg. F (900 Deg. C), it is most often used in low temperature processes and is the lowest cost of the stainless steels. Widely used in beverage, food, chemical and other industries where mild corrosion resistance is needed. It is susceptible to carbide precipitation at temperatures of 900 to 1600 Deg. F (480 to 870 Deg. C).
- 310SS (0)** maximum temperature is 2100 Deg. F (900 Deg. C), it contains 25% Chromium and 20% Nickel. Its corrosion resistance and mechanical strength is similar to 304SS but slightly better, has good heat resistance but not as ductile as the 304 series stainless steel.
- 316SS (6)** maximum temperature is 1700 Deg. F (900 Deg.C), it has the best corrosion resistance of all the stainless steel grades. It is susceptible to carbide precipitation at temperatures of 900 to 1600 Deg. F (480 to 870 Deg. C). It is widely used in the chemical and food industry.
- Inconel 600 (I)** maximum temperature is 2100 Deg. F (1175 Deg. C.) is the most predominately used sheath material due to its high temperature strength, resistance to chloride ion stress, corrosion resistance, oxidation resistance at elevated temperatures and it fairs well in nitriding environments. Inconel 600 must not be used in sulfur bearing environments.
- Other sheath materials are available for special applications. Please consult the factory for your special request. For a complete list of sheath materials go to our website at www.gicsensors.com.

- Copper (C),**
- Epoxy Glass Sheath (T),** to be used with Cooper Tipped sensors
- Tantalum (T),**
- Hastelloy X (H),**
- 446 SS (X),**
- Monel (M),** and others.

Diagram MgO

RECOMMENDED SHEATH MATERIALS (MgO)			
MATERIAL	MAX IN AIR (°F)	OPERATING ATMOSPHERE	MAX CONTINUOUS TEMPERATURE (°F)
304 Stainless	1900	ORNV	1650
310 Stainless	2550	ORNV	2100
316 Stainless	2500	ORNV	1700
INCONEL	2550	ONV ^b	2100
O = Oxidizing N = Neutral		R = Reducing V = Vacuum	V ^b = Very sensitive to sulfur corrosion

Thermocouple Tip Styles

Round Tip is the standard tip provided unless otherwise specified. It can be used in an open atmosphere, in a thermowell, in a liquid or air, and high pressures.

Flat Tip reduces the amount of "sheath" material at the tip of the probe, which can potentially affect the response time, less mass for thermal conduction into the thermocouple junction.

Drill Point Tip (118 deg tip) allows more of the tip surface to be in direct contact with the surface area of a hole, which normally has been "drilled" to the depth required, as opposed to being milled flat at the bottom.

Needle Tip is shaped to a fine point similar to a sewing needle. This facilitates the sensor tip to be inserted into an object for temperature measurement such as food processing, monitoring "skin" temperature on automobile tires at a test track. Not available in diameters below 1/16".

Reduced Tip sensor for 1/8" reduced to 1/16" (reduced section is 3/8" to 1.0") allows the "ruggedness" of the 1/8" diameter while giving the fast response of a 1/16" diameter probe. Alternative to a swaged reduced tip is a "step down" version of the reduced tip. This is facilitated by brazing or welding (depends on the diameter) a smaller diameter "MgO" thermocouple inside a larger diameter tube. This again allows the support or ruggedness of the larger diameter while maintaining the fast response of a smaller diameter sensor.

Exposed Tip is recommended where fast response is desired, and corrosive conditions are nonexistent. Commonly used in air and gas applications. The thermocouple wires are butt welded together and the insulation sealed against liquid or gas penetration into the magnesium oxide insulation. The normal exposed length is equal to 1½ times the diameter of the probe, it is not available in 0.010" diameter.

Vented Tip is an exposed junction tip design where the sensor is protected by a laser cut vented shield. Most commonly used on RTD's where fast response is desired in air and gas to protect the delicate element. It can also be used on Rigid Tube design thermocouples where the wire needs to be exposed and protected.

Diagram TS-TC









Junction Tip Style	Grounded Junction	Ungrounded Junction
 Round Tip	G(Std)	U
 Flat Tip	F	B
 118° Drill Tip	D	C
 Needle Tip	P	M
 Reduced Tips	R	Q
 Exposed Tip	-	E
 Vented Tip	-	V

Diagram JT

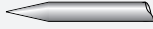
JUNCTION TYPES

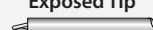

Grounded Junction the wires are welded securely into the closure end of the sheath, becoming an integral part of the junction. The response time is closest to the exposed type junction. Recommended in the presence of liquids, moisture, gas, or high pressures. The wire is adequately protected from corrosive or erosive conditions. Not recommended in 0.500" O.D.



Ungrounded Junction the thermocouple junction is fully insulated from the welded sheath end. The response time is longer, than a grounded junction. It is excellent for electrical applications where stray emf's would affect the reading, gives good noise isolation. It also is useful in applications where rapid or frequent temperature cycling occurs, and provides for longer service life of the sensor.



Separate Ungrounded junction is only available for a duplex (or triplex) style MgO material. It gives your application the usefulness of two (three for triplex) separate junctions isolated from each other and the sheath, inside one protective sheath material. Offers the same benefits as the ungrounded junction of response time, junction isolation, allowing you to send a signal to a different location or for redundancy as a back up.



Common Ungrounded junction is only available in duplex (or triplex) style MgO material. This is supplied with all the wires welded together separate from the sheath; the junction is isolated from the sheath but no isolation between the junctions. Offers similar benefits, response time, etc., as the separate ungrounded with out the junction to junction isolation.

Leadwire Terminations (T/C and RTD's)

No Split/No Strip (N): The lead wire is cut to the "A" Dimension specified. No splitting or stripping is done to the lead wire.

Split Leads (T) (Standard): Ideal for crimping and stripped wire terminals. The lead wire is cut to the "A" Dimension specified. The outer insulating jacket is stripped back 2 inches standard. The individual conductor insulating jackets are then striped back 3/8". (If a different split or strip length is required please request at time of order.)

Spade Lugs (U): Ideal for easy connection to terminal screws. The lead wire is cut to the "A" Dimension specified. The outer insulating jacket is stripped back 2 inches standard. Standard Spade Lugs are crimped to the individual conductors. (If specific size Spade Lug or different split length is required please request at time of order.)

Ring Lugs (V): For a secure connection to terminal screws. Great for high vibration applications. The lead wire is cut to the "A" Dimension specified. The outer insulating jacket is stripped back 2 inches standard. Standard Ring Lugs are crimped to the individual conductors. (If specific size Ring Lug or different split length is required please request at time of order.)

1/4" Push-On Connector (W): The lead wire is cut to the "A" Dimension specified. Outer insulating jacket is stripped back 2 inches standard. 1/4" Push-On Connectors are crimped to the individual conductors. (If a different split length is required please request at time of order.)

Bx Connector W/Spade Lugs (X): For connecting to junction boxes and panels with 1/2" knockouts or 1/2" conduit connections. The lead wire is cut to the "A" Dimension specified. The outer insulating jacket is stripped back 4 inches. Standard Spade Lugs are crimped to the individual conductors. (If specific size spade lug or different split length is required please request at time of order.)

Plugs and Jacks (1A thru 3L): Designed for quick disconnect and change out. Color coded to calibration and available in both Standard and Miniature sizes. They are available in three temperature ranges ("Std Temp" - Up to 425°F continuous, "High Temp" - Up to 660°F continuous and "Ceramic" - Up to 1200°F continuous. GIC Plugs and Jacks are also available with wire clamps. See page 60 for more information.

Diagram LT-TC

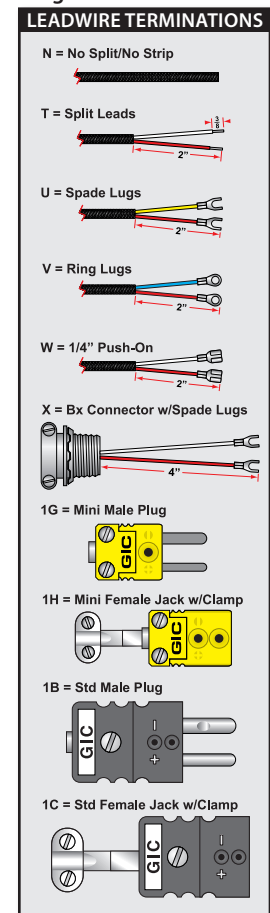

Special Options - Weld Pads (T/C and RTD's)

Weld Pads Styles

Weld Pads are designed to facilitate welding of thermocouples and RTD's to pipes, tubes and other surfaces in the field. The standard size is a 1" by 1-1/4" by 0.090" 304 stainless steel plate welded to the sensor junction. To order put a "W" in the Special Options field of the Sensor Part Number. If multiple pads are required put a "W" in the part number for each pad required. (Style, Pad size, Material, Radius is required at time of order.)

Diagram WP

- W1 = Bent to Fit Pipe (Standard)
- W2 = Formed to Fit Pipe Radius
- W3 = Milled Slot
- W4 = Milled Slot Formed to Fit Pipe Radius
- W5 = Flat Pad 90 Degrees to Sensor
- W6 = Flat Pad at Specified Angle to Sensor
- W7 = Pad Formed to Fit Pipe Radius at 90 Degrees
- W8 = Flat
- WZ = Other (Consult Factory)

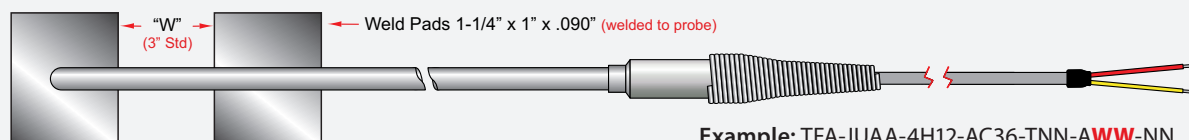
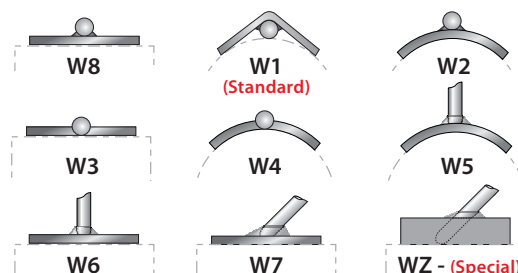

Example: TFA-JUAA-4H12-AC36-TNN-AWW-NN

Special Options (T/C and RTD's): Chose as many special options needed. If you require two of the same option like two Weld Pads or ID tags put a letter for each item required.

- Option A - **Special Limits of Error (T/C only):** This qualifies the accuracy of the sensor based on specified standard test points (EMF vs Temperature) set by the industry. This designates the highest tolerances available. (See page 13 for more info.)
- Option B - **RTD Transmitter:** Head mounted transmitter, fully Linearized, Pt100 input only. **Mp82800R** (See page 70 for more info.)
- Option C - **Programmable RTD Transmitter:** Head mount transmitter, fully linearized. Push-button Programmable, can be programmed in the field. Pt100 RTD 3-wire input only. **Mp82850R**. (See page 70 for more info.)
- Option D - **Universal Transmitter:** Scalable over the entire range of 8 RTD's and 12 Thermocouples. Fully-Isolated; Fully-Linearized. Hart protocol option. **Mp82700** (See page 70 for more info.)
- Option E - **Economy Multi-input transmitter:** – Pt100 RTD & Thermocouples. Fully-linearized head mount transmitter. **Mp82800**. (page 66)
- Option F - **Field Bendable:** Sensor is able to be bent in the field. This option must be specified for Rigid Tube assemblies, T/C and RTD. Mineral Insulated (**MgO**) assemblies are field bendable – option not required.
- Option G - **Shielded leadwire:** Shield with Drain Wire Reduces Electrical Noise. (Specify -Shield open or Shield grounded to probe)
- Option H - **High Vibration:** Assemblies are reinforced to help prevent damage/failure in extreme applications.
- Option I - **SS ID Tag:** Product Identification plate. (Electro-etching standard)
- Option J - **Coated Armor:** Provides a moisture seal for this durable and abrasion resistant wire protection. PVC or Teflon.
- Option K - **(Open)**
- Option L - **Mating Connector:** Assembly will be supplied with a mating connector.
- Option M - **MgO Construction:** Metal sheathed mineral insulation provides best construction for high temperature or heavy vibration applications. Multiple sizes and materials.
- Option O - **Separate Ungrounded:** Isolated junction type used in dual and triplex MGO assemblies (See Diagram "JT" page 15.)
- Option P - **Electro-etching:** Part number or other information permanently etched on probe sheath.
- Option Q - **Ground Screw:** For head assemblies if a ground screw is required. Not available on all connection head styles.
- Option R - **Faster Response Construction:** Greatly increases response time in ungrounded/Isolated sensors.
- Option S - **Spring Loaded:** Allows probe retraction for best contact with process surface. Pressure on the junction tip provides and maintains faster response.
- Option T - **Coated Probe:** Sheath is sealed with Teflon or PVC to provide added protection in highly corrosive applications.
- Option U - **Butt Welded Junction:** Optional welding procedure of wire thermocouples instead of twist welded.
- Option V - **Field Cuttable:** RTD probes can be cut down to a minimum 3" length using a standard tube cutter. Sealed construction for outdoor/moisture applications. Also available on some Thermocouple assemblies.
- Option W - **Weld Pad:** Tig welded to sheath. Formed to match tube diameter. Used to weld sensor to process surface. (See page 16)
- Option X - **X-Ray Junction:** Sensors are x-rayed in two or four planes for weld integrity and junction location.
- Option Y - **Certificate of Conformance or Calibration:** Conformance certifies the material being provided meets the specifications and requirements of the purchase order. Calibration certifies the sensor at specific temperatures. If a Certificate of Conformance is selected, specify the number of points and temperatures.
- Option 2 - **High Temperate Oxidation Coating:** A special coating to help prevent oxidation at high temperatures.
- Option 3 - **Test at Process Temperature:** Sensor tested at required temperature (2000°F max) for extended period or cycled. The sensor is tested at a specific temperature point for a specified period. This is not a calibration certificate.
- Option 4 - **BX Connector:** 1/2 inch BX connector added to the sensor leadwire where required. (Specify Location)
- Option 5 - **Soak Test: (Ungrounded junctions only)** Sensor junction is immersed in water for a minimum of four hours to check for potential cracks in the sheath or weld. The sensor must then pass a 100 VDC meg check immediately after it is removed from the water. This test is standard on all GIC utility sensors.
- Option 6 - **Tip Sensitive RTD:** For applications that require a tip sensitive element instead of the standard area sensitive element.
- Option 7 - **Rigid Tube Construction:** Sheath is made from rigid metal tubing instead of MgO filled.
- Option 8 - **No Heat Shrink on Probe:**
- Option 9 - **No Crimp on Probe:**
- Option Z - **Special: (Consult Factory)** For anything special about a assembly that isn't called out elsewhere. Put a "Z" for each special option needed and give a detailed description for each in the order notes.

For more information on Special Options: www.GICThermodynamics.com

Fittings

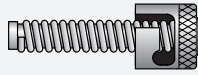

The fixed bayonet fitting with lockcap provides spring loaded pressure designed for holding probes in place without tapping or drilling. For use with .188" diameter probes only.

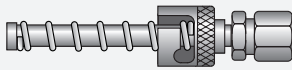

An Adjustable bayonet compression fitting, designed for use with .125" probes, can be positioned at the time of installation. (Available from stock. See page 10)

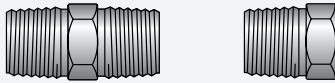

Fittings are brazed or welded to the sheath at the time of manufacture. Available in multiple bore sizes, threads (NPT and metric), materials and designs.

One time adj. Compression Fittings (Stainless Ferrule)

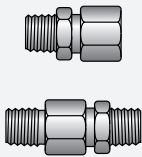

Fittings can be positioned to the exact length at the time of installation. The metal ferrules, brass or stainless, cannot be moved or repositioned once they are installed and compressed.

Readjustable Compression Fittings

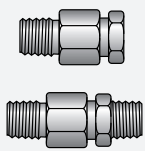

The use of various sealant gland materials allows the compression fitting to be repositioned several times after it has been installed. The glands are rated up to 3000 psi and the following temperatures:

*Teflon® gland (Standard) (400°F)
Neoprene gland (200°F) and Lava Gland (1200°F) Also available.

Flanges (T/C and RTD's)



GIC can provide any size flange, including custom designs, in large or small quantities. Fixed Flanges can be welded or brazed on. Adjustable flanges are also available.

For complete list of Sheath Fittings, Transitions, Transition potting materials and specifications:

www.GICSensors.com

Transitions (Style F - T/C and RTD's)

Durable stainless tube which allows for the mechanical and electrical attachment of the lead wire to the metal sheathed, mineral insulated thermocouple or RTD probe. Standard potting is epoxy based and moisture resistant to 500°F. The Hi-Temp potting is ceramic based and good for temperatures to 1100°F. Custom configurations and compounds for extreme temperatures and conditions are also available.



A = Standard Transition w/Relief Spring (500°F)(Std)
C = Hi-Temp Transition w/Relief Spring (1100°F)



B = Standard Transition (500°F)
D = Hi-Temp Transition (1100°F)

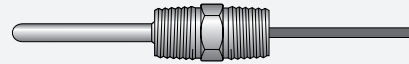

E = Hex Nipple Transition (500°F) Specify size.
F = Hi-Temp Hex Nipple (1100°F) Specify size.

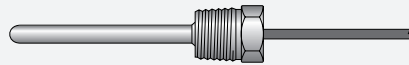

G = Bushing - Threads toward Tip (500°F) Specify size.
H = Hi-Temp Bushing - Threads toward Tip (1100°F) Specify size.

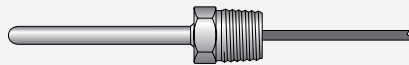

I = Bushing - Threads toward Leads (500°F) Specify size.
J = Hi-Temp Bushing - Threads toward Leads (1100°F) Specify size.



K = Smooth Transition (500°F)
L = Hi-Temp Smooth Transition (1100°F)



M = Mini-Transition (500°F)
O = Hi-Temp Mini Transition (1100°F)

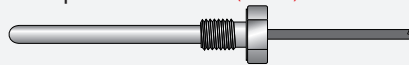

P = Bolt Transition - Threads toward Tip (500°F) Specify size.
Q = Hi-Temp Bolt - Threads toward Tip (1100°F) Specify size.

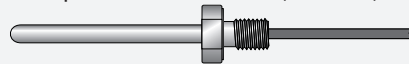

V = Bolt Transition - Threads toward Leads (500°F) Specify size.
W = Hi-Temp Bolt - Threads toward Leads (1100°F) Specify size.



R = Compression Fitting - Threads toward Leads (500°F) Specify size.
S = Hi-Temp Compression Fitting - Threads toward Leads (1100°F)



T = Compression - Double Ended (500°F) Specify size.
U = Hi-Temp Compression - Double Ended (1100°F) Specify size.



N = No Transition - Lead wires welded or brazed to sensor
Z = Special